

JETPRO S-AIR

Economically priced, the JETPRO S-AIR is an air-powered hydraulic power pack that combines industry-leading reliability with lightweight design. This 2-stage pump features a one-gallon reservoir for lightweight portability. The intuitive design of the one button control ensures improved speed and efficiency in the field. This system is part of our ATEX-approved bolting package for explosive environments.

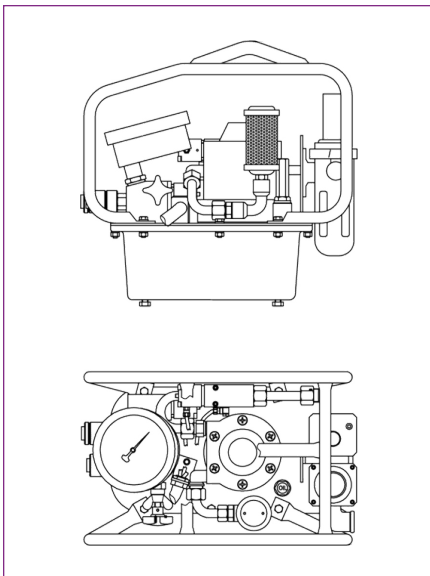

PUMP SPECIFICATIONS AND FEATURES

Air Consumption	1,900 cu.in./sec. (31 l/sec.)
Gauge	0-10 k PSI (+/-1% Accuracy)
Reservoir Capacity	0.8 gals. / 3.00 l
Stages	2
Weight	35 lbs. / 16 kg
Maximum Oil Flow Rate	370 cu. in./min. / 6 l/min.
Oil Cooler	No
Protective Caging	Yes
15' Remote Control	Yes