

HY-TWIN 230

This high-powered, twin-motor, 3-stage pump provides twice the speed and oil flow of any other available system. Ideal for large hydraulic or multi-tool systems, the HY-TWIN 230 delivers high power for large torque wrenches (10,000 ft.-lbs. and up) without compromising speed. The five-gallon reservoir provides enough oil to power up to four large tools at once, and the built-in casters allow for increased mobility.

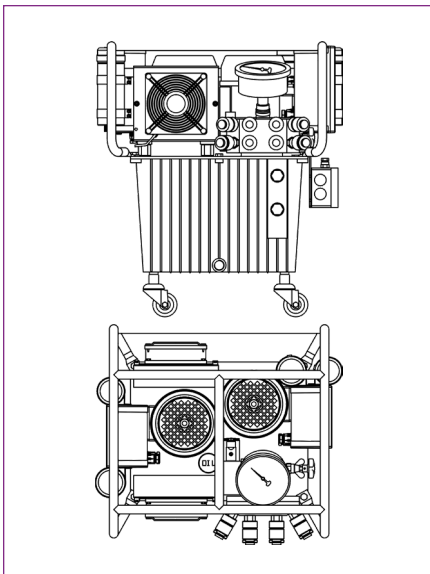

PUMP SPECIFICATIONS AND FEATURES

Power	230v (30 Amp) 115V: 1Ph 90-125 / 60Hz 230V: 1Ph 200-230V / 50+60Hz 400V: 3Ph 400-460
Gauge	0-10 k PSI (+/-1% Accuracy)
Reservoir Capacity (Tank optional)	5 gals. / 19 l
Stages	3
Weight	112 lbs. / 51 kg
Maximum Oil Flow Rate	1,480 cu. in./min. / 24 l/min.
Oil Cooler	Yes
Protective Caging	Yes
15' Remote Control	Yes